

Chapter 4 Review #2

Name: _____

Classify each based on their angle measures and their sides.

1.

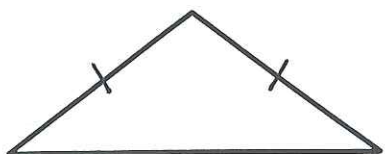

2.



3.

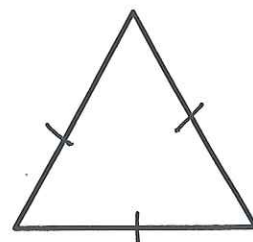

For each of the following, use what you know about triangles and their angles to find all of the missing angle measures.

4.

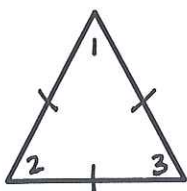

5.

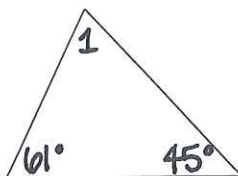

6.

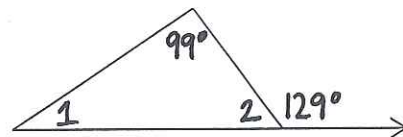

7.

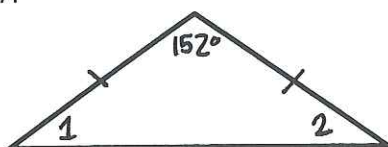

8.

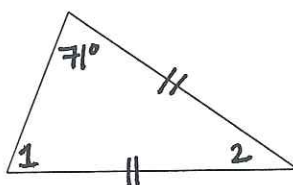

9.

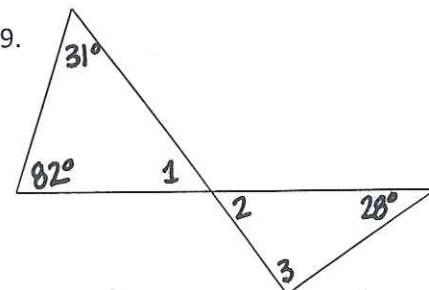

10.

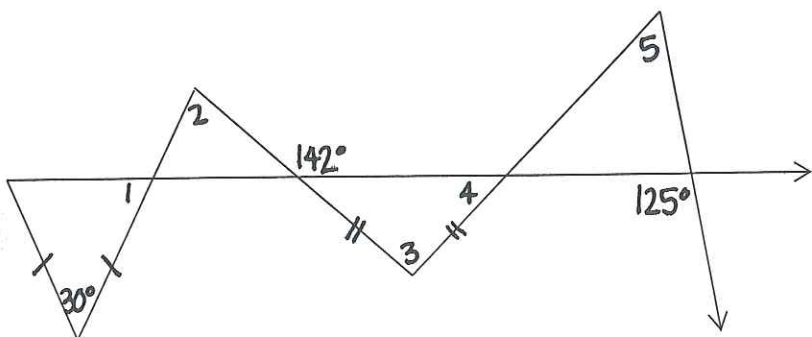

11.

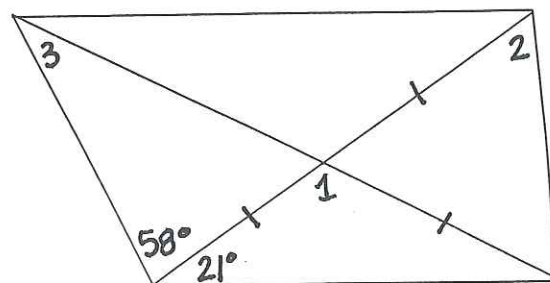

For each of the following, solve for x .

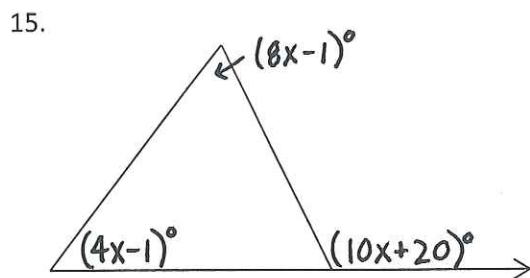
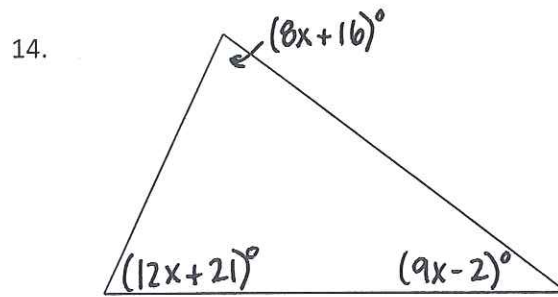
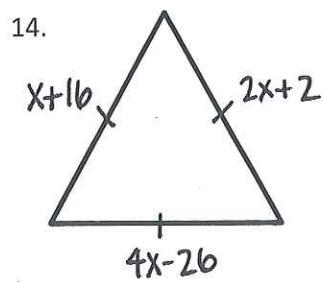
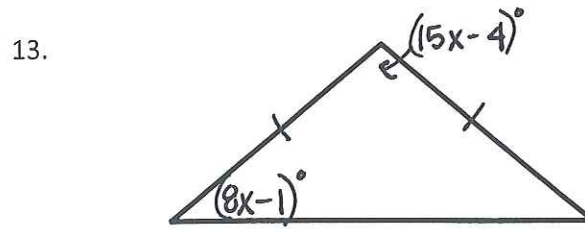
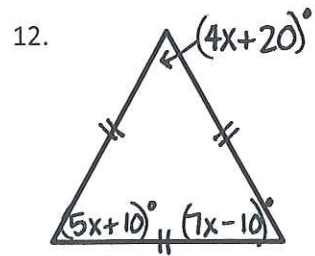

16. The triangle below is an equilateral triangle.

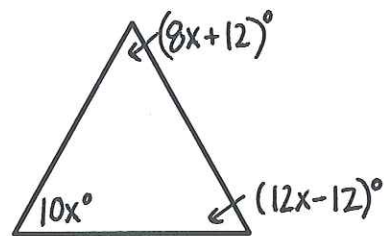

17. $\triangle ABC$ is an isosceles triangle with $\angle C$ as the vertex angle. If $\overline{AB} = 5x - 7$, $\overline{BC} = 3x + 1$, and $\overline{AC} = 4x - 2$, solve for x .

For each of the following, either fill in the boxes or create your own flow chart.

18. Given: ABCD is a parallelogram

Prove: $\triangle ABC \cong \triangle CDA$

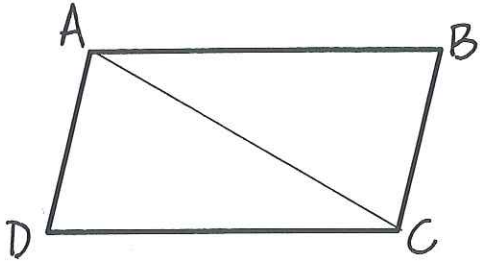

19. Given: The picture below and that \overline{FH} bisects $\angle EFG$.

Prove: $\angle E \cong \angle G$

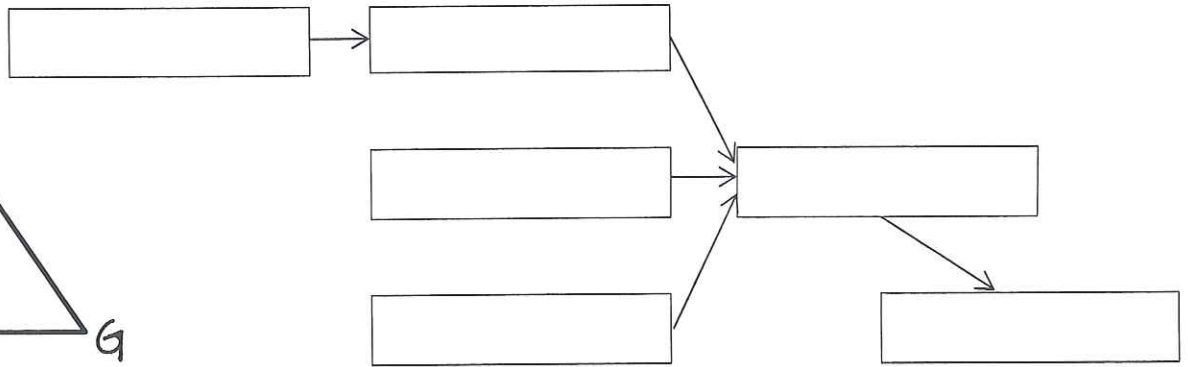
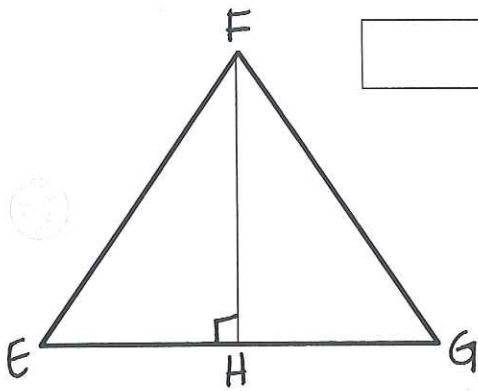

20. Given: $\overline{AB} \parallel \overline{DE}$ and C is the midpoint of \overline{BE} .

Prove: $\overline{BA} \cong \overline{ED}$

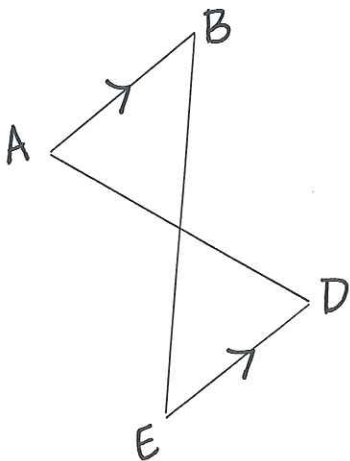

21. Given: \overline{BE} bisects $\angle ABC$, and E is the midpoint of \overline{AC} .

Prove: $\triangle CBE \cong \triangle ABE$

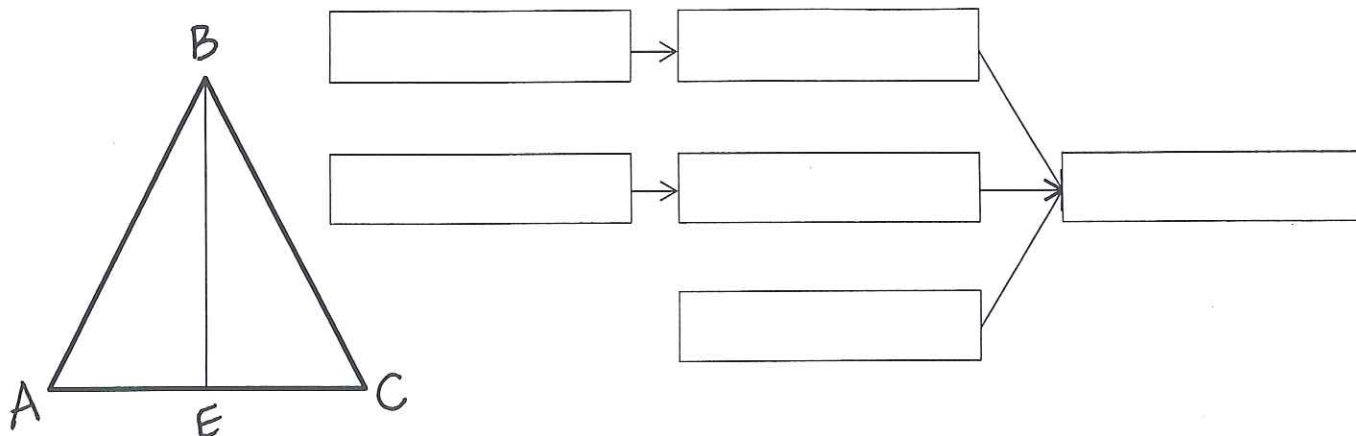

Identify which postulate or theorem justifies the triangle congruence. If none of them work, just write "none".

22.

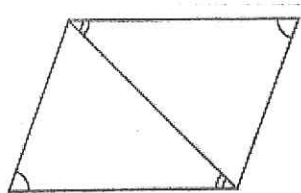

23.

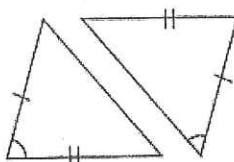

24.

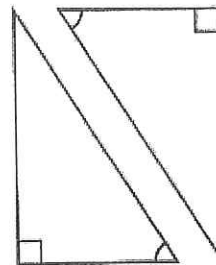

25. Find the measures of the sides of the triangle if the vertices of $\triangle MSU$ if $M(-3, 3)$, $S(-1, 3)$, $U(-3, 1)$. Then classify the triangle by its sides.